

Operators Manual

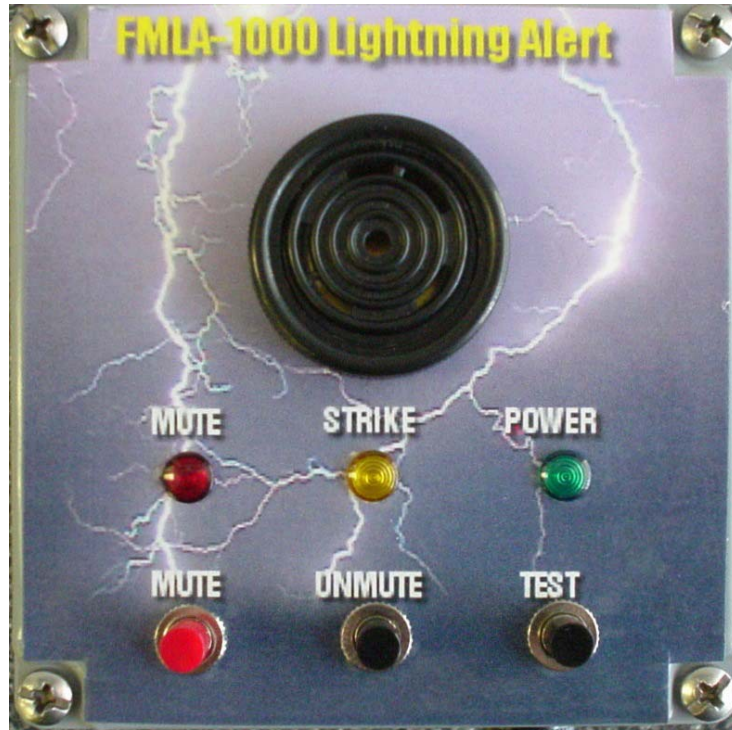

FMLA-1000 Fixed/Mobile Lightning Alert System

Basic and Pro Models

ItWorks/WeatherShop
3008 Cohasset Road
Chico, CA 95973
530-899-8434
www.weathershop.com

Features of the FMLA-1000

- Detects unseen cloud-to-ground lightning. Lightning is hard to see at a distance in the daytime.
- The alarm sounds 3 seconds for each unseen lightning flash. Severe storms cause continuous alarm. Alarm automatically resets itself after each lightning flash.
- Loud Piezo-Electric Klaxon provides piercing 2.8 Kilohertz tone at 83dB, getting attention over background or automobile motor noise.
- Unlike other lightning detectors on the market, ours is the first to use a completely digital lightning sensor. All sensor electronics are self contained and hermetically sealed in the antenna module. A digital sensor gives more dependable early warnings!
- Test button to allow for a manual test of audible tone and LED.
- Two year 9-volt battery life for worry-free uninterrupted operation. Automatic system test when first turned 'ON' assures you that the system is working. (note: 12VDC powered model does not use an internal battery)
- The 25 mile range gives you plenty time to clear the area or halt operations before the storm arrives within 'striking distance'.
- This unit warns you before you hear the thunder. You are in strike danger before you hear thunder.
- Omnidirectional sensor detects unseen in-cloud lightning flashes from every direction, including directly overhead!
- Warning performance and range is not affected by cold, heat, haze, fog, pollution, smog, rain, etc.
- The external lightning sensor is hail-proof and weather-proof. It is a single self-contained unit.
- Compact Internal Alarm box measures 4" x 4" x 4", has screw-down cover with screws, and rubber gasket for moisture seal. Made of molded PVC and has four mounting holes and screws for easy wall mount. Can easily be adapted/drilled to work with conduit if required to run cables via conduit.

Additional features for the Pro Version 12VDC Powered Model:

- 12 Volt DC input jack for van power/backup power, can also be powered by External 120VAC Wall Transformer. Extremely low current draw, less than 10 milliamps in standby mode, approximately 50 milliamps peak when alert is sounded.
- 12 Volt DC power LED indicates "power good" when running on automobile/van 12VDC source.
- 12Volt DC Fuse and 12Volt DC power reversal protection.
- Mute and Unmute buttons with automatic internal reset timer (time is DIP switch settable) allows you to mute the audible alarm temporarily, but ensures that the detector audible alarm can't be permanently disabled. Internal DIP switch prevents tampering.

- Mute Status LED shows when unit is muted.
- Optically-Isolated (3.5 Kilovolts max voltage isolation) Open Collector Relay driver output is included on 4 pin power/relay jack. Matching plug included.
- Mute function also silences Opto-isolated output to prevent external alarm from sounding during live shot.
- All cable connectors are mechanically secured to prevent loss of connection due to vibration.

Applications:

Utility Crews, ENG Crews, Golf Courses, Schools, Ball Fields, Beaches, Public Parks, Swimming Pools, Recreational Lakes, Home, or anywhere early warning of approaching lightning storms is needed.

Fixed or Mobile External Mounting:



FMLA-1000 mounted on TV antenna mast



FMLD-1000 antenna mounted on TV Live Van

The FMLA-1000 is Supplied with a pole mounted Lightning Sensor and with a 50-foot cable that plugs into the front of the detector. Easy mounting with standard antenna mounting hardware (U-bolts), no special tools are needed. The cable can be cut to length and spliced as needed.

FMLA-1000 Basic Internal Battery Powered Model Includes:

- FMLD-1000 Hermetically Sealed Weatherproof Antenna Module
- FMLA-1000 Internal Alert Unit with Klaxon and Strike LED
- Test Switch
- 50' pre-wired Antenna Cable with 1/4" phono plug
- 9-Volt Alkaline battery
- Antenna Mounting hardware
- Printed User guide

FMLA-1000P Professional 12VDC Powered model Includes:

- FMLD-1000 Hermetically Sealed Weatherproof Antenna Module
- FMLA-1000P Internal Alert Unit with Klaxon, Strike, Mute, and Power LED's
- Mute and Unmute Switches to silence Klaxon for user programmable mute time up to 1 hour
- Mute programming DIP switch is settable in 5 minute increments, internal to prevent tampering
- Test Switch
- Auto reset of Mute after user programmable time to prevent "forgot to turn it back on" problem
- 3.5 Kilovolt Opto-isolated output (Open collector transistor) for driving external relays or sirens
- 50' pre-wired Antenna Cable with 1/4" phono plug
- 4 pin external 12VDC power/opto-isolated Open Collector Relay output jack and plug (user self wires plug provided)
- External Fuse holder for 12VDC power protection
- 12VDC Power reversal protection diode protects unit in the event of incorrect wiring
- Antenna Mounting hardware
- Printed User guide with interface schematic and application note

WARNING:

Improper use of the FMLA-1000 can result in an SHOCK, ELECTROCUTION, and/or FIRE HAZARD. To prevent such hazards, heed the following:

Do NOT install the external sensor near power lines, phone lines, or other devices carrying live electrical current. Shock or electrocution could occur if the external sensor should come in contact with live electrical wiring or circuits.

Do NOT attempt to install the FMLA-1000 as a replacement for or next to a lightning rod on a building.

Do NOT use the FMLA-1000 as a personal hand-held alerting device while outside in thunderstorms.

Do NOT install or experiment with this or any other electric or electronic equipment when lightning storms are nearby. Remember that lightning has the ability to build up and suddenly strike objects and people over 15 miles away from thunderstorms ("a bolt from the blue").

Do NOT use the FMLA-1000 as your only source of weather information, always stay abreast of weather conditions from other sources.

WARRANTY:

The FMLA-1000 is intended only for meteorological and educational uses. Use of the FMLA-1000 for the aid in the safety of life and/or property is left completely up to your judgment. The manufacturer assumes no express or implied warranty that the FMLA-1000 will prevent or immediately warn of a lightning strike direct to your location. If the sky "looks threatening", get out of the weather. There is always a "first lightning strike of the storm" somewhere. The FMLA-1000 is intended to detect approaching cloud-to-ground lightning strikes from established thunderstorms, and not the buildup of the static charges in clouds before lightning strikes.

The FMLA-1000 is warranted to be free of defects in materials and workmanship for a period of 1 year from the date of purchase. During that period, the manufacturer will repair or replace, any FMLA-1000 unit that fails to perform its advertised functions. The warranty will not be honored for those units that have been abused, improperly mounted, or that have been hit directly or by close proximity lightning strikes. While the manufacturer believes the product can perform well in lightning storms, no electronic device can ever be completely protected from direct lightning damage.

Mounting the FMLA-1000

Installing the External Lightning Sensor

The Lightning Sensor must be mounted outdoors to take full advantage of the long-range detection features. Range is adjustable by how high above ground level the Lightning Sensor is mounted. Firmly screw the whip antenna on to the antenna connector after the sensor is attached to the pole as shown at right. Use the U-bolt provided. You can use one U-bolt or two, depending on your preference.

For fixed operation at a home or business: The Lightning Sensor must be mounted on an earth-grounded metal pole. This is a metal pole that is mounted so that its base is at least 2 feet underground in soil. A ground rod (available at your local hardware store, or "Radio Shack") can be used to ground the pole further. (Do not mount the Lightning Sensor to a plastic pole). The Lightning Sensor's cable must be wrapped around the pole 10 times or more before it enters your house, as shown in the photo below, so that capacitive grounding will result.

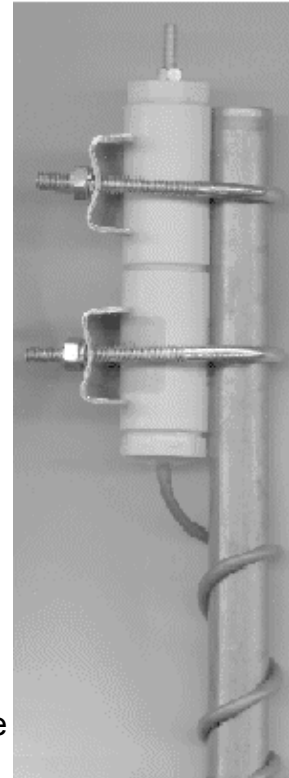

For Mobile Operation: If used portable on a camera tripod, or mounted to an automobile or van, the tip of the antenna should be 8-10 feet above ground to allow minimum of 25 miles detection range.

When used on a tripod, allow all of the extra cable to lay on the ground below the tripod. This will allow capacitive grounding to earth to occur. It is OK to keep the wire coiled, as long as it lays on the ground.

When using on an automobile or van, the mounting pole should be metal and attached to the vehicle body. While not absolutely required, a trailing static ground strap (available at auto and truck supply stores) will increase the capacitive grounding of the vehicle body to earth, and thus increase the sensitivity of the FMLA-1000 detector.

When the FMLA-1000P "Professional Model" is used in an automobile or van and connected to the 12 volt DC power system, ground is attached to the auto body. This usually provides enough of a ground plane to get good detection within 25 miles.

Mounting and detection range:

Elevation of the FMLA-1000 Lightning Sensor above the ground sets the typical lightning detection range approximately as shown below. Terrain and local obstructions may reduce range. Elevate sensor if detection range is not great enough. If range is too great, mount sensor closer to ground using a shorter pole. Do not set the range less than 20 miles, as lightning can strike up to 15 miles away from a thunderstorm!

Antenna tip **8-10 feet** above ground for approximately **20 miles** detection range.

Antenna tip **15 feet** above ground for approximately **50 miles** detection range.

Antenna tip **20 feet** above ground for approximately **100 miles** detection range.

Mounting considerations for the FMLA-1000 Basic model when mounted outside on a pole

- Select a location far away from power lines, antennas, and other outdoor wires, and electrical equipment. Avoid mounting near a chimney as soot/ash build up on Lightning Sensor's plastic casing will decrease detection performance.
- Mount the Lightning Sensor to the top of a metal pole as shown in the photographs. Do not clamp to any other part of the sensor except the base as shown. The top of the base should be even with the top of the metal pole.
- Dig a hole 2 feet deep (or more) for the pole to sit down into. This hole will provide earth grounding for the pole and the Lightning Sensor. Some ready-mix concrete may be used in the bottom of the hole to help stabilize the pole. It is important however the pole must make contact with soil - fill up the hole partially with soil so the bottom of the pole maintains earth contact. (If concrete is used, use a 5-foot fitted pole, so that the sensor (mounted on top another 5 or 10 foot fitted section) can be easily removed without digging up the whole setup.
- Safely erect mounting pole with Lightning Sensor securely attached, and cable wrapped around pole at least 10 times, as shown in the photographs on previous page. If your pole is over 15 feet tall you may want to stabilize it using nylon guy wires.

Operation of the Control Panel

Preparing the FMLA-1000 BASIC model for operation

1. A 9-volt battery has been factory installed before shipment.
2. Check to make sure the 9-volt battery is mounted securely to its connector by opening the compartment (remove four screws). Replace the cover once verified.
3. Plug the lightning sensor into the front panel jack. The alarm will sound for 3 seconds and the LED "Strike" light will glow for 3 seconds.
4. Press the TEST button once to verify again. The alarm will sound for 3 seconds and the LED "Strike" light will glow for 3 seconds.

Use of the FMLA-1000 BASIC Model

For home or business use: Place the Model FMLA-1000 on a desk or window sill, or mount it on the wall where it will be out of the way. The unit is now working and ready to detect lightning. Buzzer sounds and LED glows 3 seconds each time lightning is detected.

For mobile use: It is suggested that the FMLA-1000 be permanently mounted inside the vehicle using the four mounting holes on the Control Panel box. If needed, a conduit fitting can be drilled into the Control Panel box to allow the detector cable to be routed outside via conduit.

IMPORTANT! BATTERY LIFE:

Typical life of a 9-volt battery will be 1 year of continuous use in the Model FMLA-1000. Do NOT use a rechargeable battery. Check the battery once every month (or before each use, if desired): Press the TEST button. The alarm will sound once for about 3 seconds and the LED "STRIKE" Light will illuminate .

If the alarm volume is low or the LED "STRIKE" light is dim, replace the battery. Use only an "alkaline" battery for longest life. The Model FMLA-1000 draws no battery power unless it detects lightning. Its unique patented circuit design only completes a circuit to the alarm when a strong electro-static discharge has occurred within detector range.

Use of the FMLA-1000P PROFESSIONAL Model

For mobile use: It is suggested that the FMLA-1000 be permanently mounted inside the vehicle using the four mounting holes on the Control Panel box. If needed, a conduit fitting can be drilled into the Control Panel box to allow the detector cable to be routed outside via conduit.

Connecting the external power and relay output connector:

The diagram below shows the 4 pin power and relay connector as seen from the FRONT:

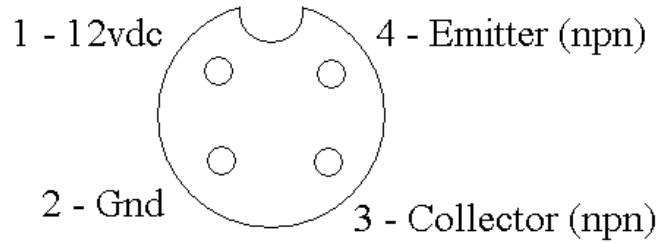

Using the 4 provided:

Pin Plug

Connect Pin 1 to Positive 12 Volts DC

Connect Pin 2 to Negative 12 Volts DC (chassis ground in automobile)

Note: if power is accidentally applied reversed, an internal protection diode will prevent the FMLA-1000 from sustaining damage.

Pins 4 and 3 are connected to the Emitter and Collector of an NPN Opto-Isolator Transistor (Fairchild 4N37) as shown below. This can be used to drive an external relay, klaxon, or other device that can accept a pulse on/off input. A pull-up resistor of approximately 1K ohm can be wired directly into the 4 Pin plug housing if desired between 12VDC pin 1 and Collector pin 3.

FUSE:

The FMLA-1000 uses a 250 milliamp (1/4 amp) fast blow fuse. It is mounted in a screw mount fuse holder on the side of the unit.

NOTE: the MUTE switch also disables the Opto-Isolator output

Using the Opto-Isolated Relay Output

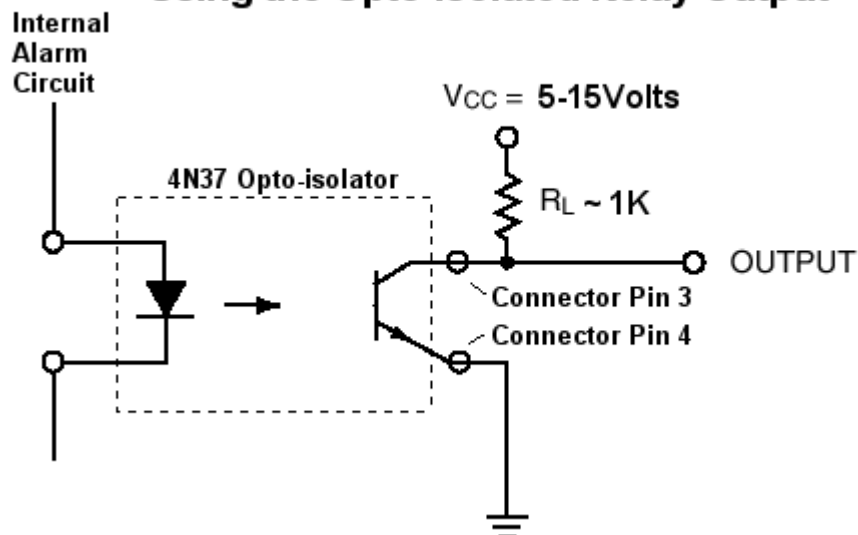

Suggested Relay Driver Circuit

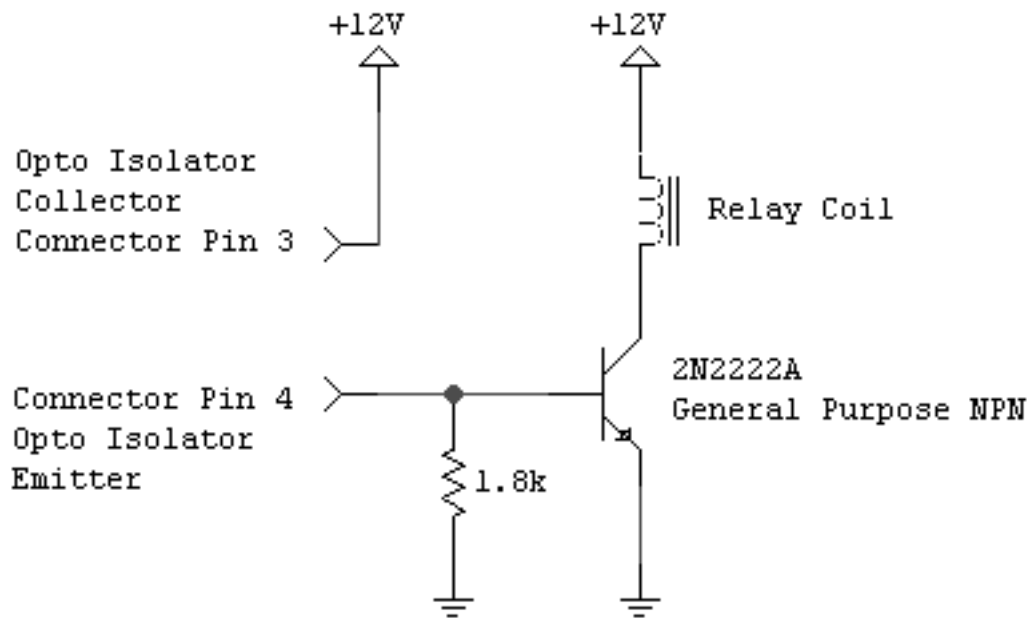

See addendum on last page

CONTROL PANEL FUNCTIONS:

POWER LED: Glows when connected to the automobile 12VDC power system.

STRIKE LED: Glows each time a lightning strike is detected. May sometimes glow briefly without buzzer sounding when a weak strike is detected.

MUTE LED: Glows when the unit is silenced by the MUTE button. Turns off when the UNMUTE button is pressed.

TEST SWITCH: Press briefly to test the FMLA-1000. Buzzer will sound, STRIKE LED will glow.

MUTE SWITCH: Press to silence the buzzer. Mute time is determined by the setting of the internal DIP switch.

UNMUTE SWITCH: Enables the buzzer, buzzer may sound briefly when UNMUTE is pressed.

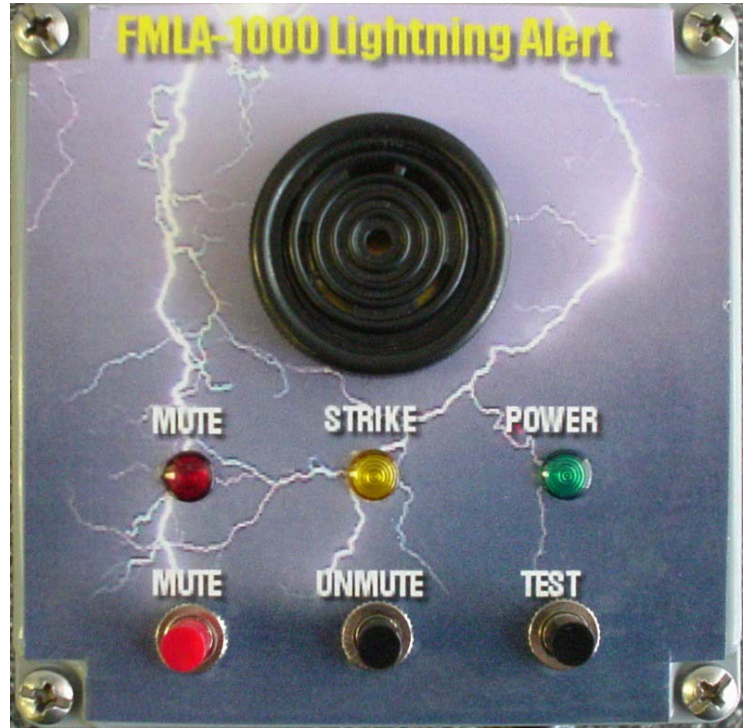

Setting the Internal DIP switch to control the MUTE time

The FMLA-1000P Professional model comes with an internal 12-position DIP switch that can be accessed by removing the four cover screws. The setting of this switch determines the time that the MUTE function will last. The purpose of this is to allow the operator to silence the alarm for a preset period to keep the alarm from interfering with conversation use of a telephone, radio, or microphone. After the MUTE switch is pressed, the timing circuit will keep the buzzer and STRIKE LED off for that preset period, then automatically re-enable.

This table shows the DIP switch number and the MUTE delay. Set only one switch "ON"

1	2	3	4	5	6	7	8	9	10	11	12
5min	10min	15min	20min	25min	30min	35min	40min	45min	50min	55min	1hour

The FMLA-1000 is factory preset to 20 minutes MUTE delay.

(Due to component tolerances actual times may vary slightly)

Testing the FMLA-1000 using “simulated lightning”

If desired, you can test the FMLA-1000 by using a cigarette, gas grill, or fireplace lighter that has a Piezoelectric “sparker” to ignite the Butane in the lighter. These are commonly sold at department stores and hardware stores and advertised as “flintless lighters” or as “Insta-Match” or “gas lighter” shown at right.

They usually cost less than 5 dollars and are characterized by a trigger that you have to exert force to, which results in a “snap” and a spark. This spark is usually between 1 and 3 thousand volts and is enough to trigger the FMLA-1000 detector at close range.

To test the FMLA-1000 using a Piezoelectric lighter:

- Hold the lighter tip about 6 inches from the FMLA-1000 whip antenna
- Set the lighter for a “minimum flame”
- Depress the lighter switch to make a spark
- The FMLA-1000 buzzer should sound and the STRIKE LED should illuminate
- If you don’t get a detection right away, you may have to reposition the lighter closer or re-orient the tip

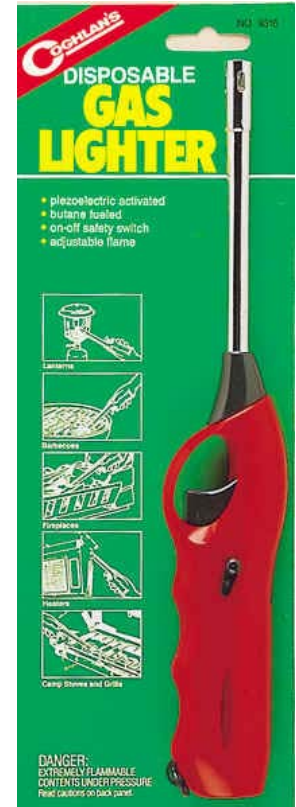

TROUBLESHOOTING AND FALSE ALARM PROBLEMS:

The FMLA-1000 is designed to detect electrostatic discharge from lightning, but it can also be triggered by other sources of static electricity. Here are a few possible causes:

Spark Plug noise on a vehicle- though rare, some badly shielded engines may cause false alarms. The solution is to install resistive spark plug wires.

Welding Equipment – Electric Welders obviously generate sparks during the welding process which will cause the FMLA-1000 to alarm.

Electrical Sparking – anything that generates a spark can trigger the sensor, EG: light switches, contactors in Air Conditioners or Air Compressors, etc. Spark suppression capacitors or snubbers can be placed across the contacts to minimize the problem – talk to your electrician about installing spark suppression equipment or snubbers.

Touching the antenna- static charge on the human body is often enough to trigger the detector

On a vehicle- driving under a tree branch where leaves may contact the antenna could set off the detector in dry climates

Driving a vehicle- sometimes certain tires can cause a static buildup and discharge. You can solve this by placing a dragging ground strap under the vehicle. These are available at auto and truck suppliers.

Mobile Radio Antennas- while the FMLA-1000 has been successfully used right next to CB radio, VHF, and UHF radio transceivers. Some unforeseen circumstance may cause static induced by RF emissions to discharge somewhere on the vehicle. The solution can usually be found in making certain that all cable and coax connectors are tightly secured, eliminate corrosion, or re-orient the transmitter or detector antennas.

Relay Kit Addendum

The FMLA-1000s are built to order.

Due to a redesign of the circuit board the relay kit can now be built into the FMLA-1000 Pro when the device is constructed.

The 5 amp rated N/O contacts are available on the power connector. They are connected to pins 3 and 4 formerly the Opto-isolator emitter and collector pins. The relay output is polarity dependent. Pin 3 is negative and Pin 4 is positive.