

WIRELESS REPEATER

WITH SOLAR OR AC-POWER

The Wireless Repeater receives data from any DavisTalk™-compatible transmitter and re-transmits it to any DavisTalk-compatible receiver. The repeater extends the transmission range and improves reception between the transmitter and the receiver.

Each repeater has a transmitting and receiving range of up to 400' (120 m) depending upon the terrain. The repeater can listen for up to eight different transmitter signals and can pass those signals on to another repeater or to any number of receivers.

Note: *The Wireless Repeater operates on a low power frequency that does not require an FCC license.*

The repeater allows you to put together your weather system in a number of different ways. The most common setup is to install the repeater between a transmitter and a receiver to improve reception. You can also install a *chain* of up to eight repeaters to carry the transmitter's signal over a longer distance, or around obstacles. Or, you can establish a *network* of weather stations by linking the chain of repeaters to up to eight different wireless stations.

This manual describes three different setup options in separate sections based on how many repeaters and transmitters you plan to install:

- ◆ The first section, "Single Transmitter, Single Repeater Installation" on page 3, discusses the most common and simplest installation—that of one transmitter, one repeater and one or more receivers.
- ◆ The second section, "Daisy-Chain Installation (Multiple Repeaters)" on page 10, discusses daisy-chaining up to eight repeaters in succession to increase the range between a single transmitter and one or more receivers.
- ◆ And the third section, "Network Installation (Multiple Transmitters)" on page 12, discusses setting up a complex network of transmitters, repeaters, and receivers.

These setup instructions apply whether you have a solar-powered or an AC-powered repeater.

Components

The Wireless Repeater includes the following components. Please be sure you have everything you need for either the AC-powered or the solar-powered model.

Wireless Repeater Components

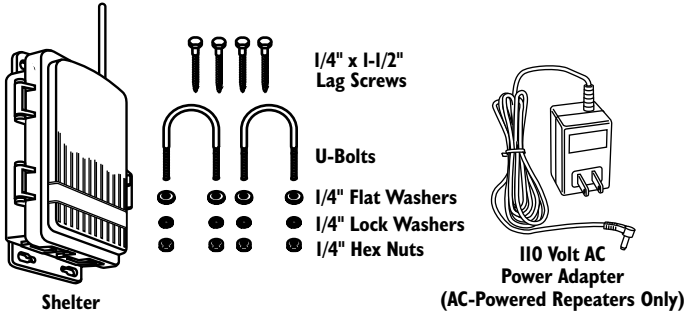

Tools and Materials

You may need the following tools and materials for either the AC-powered or solar-powered model.

- ◆ Adjustable Wrench
- ◆ Medium Flathead Screwdriver
- ◆ Medium Phillips Screwdriver
- ◆ Compass or Local Area Map
- ◆ Pencil or Other Pointed Object

Single Transmitter, Single Repeater Installation

If you have just one DavisTalk transmitter and just one repeater, simply follow the instructions below to install your system. If you have a more complex setup that involves multiple repeaters or multiple transmitters within 400' (120 m) of each other, see "Advanced Installations" on page 10.

Quick Install Instructions

First off, open the repeater housing. Inside, you should see a green circuit board in the upper part of the right-hand side of the box. Compare the circuit board in your repeater with the picture below. You should be able to identify the Transmitter ID DIP switch component with its eight switches on the left edge of the board, the Repeater ID DIP switch, recognized by its four switches, and finally the two test LEDs in the upper left part of the board.

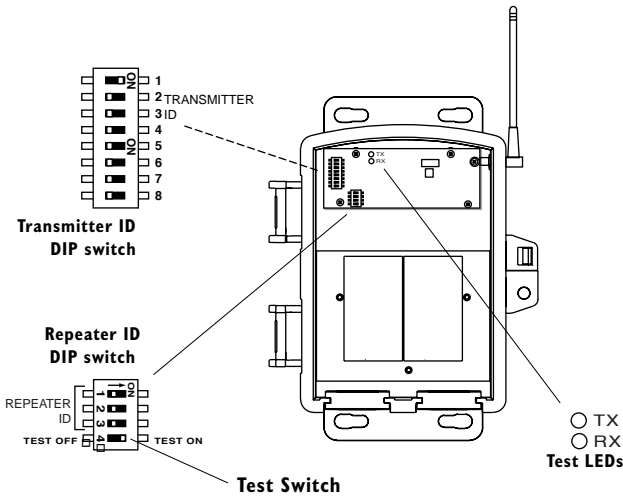

The DIP switches are used to configure the repeater.

- ◆ If you're using only one repeater, the Repeater ID DIP switches are not required. Leave them at the factory settings (all off).
- ◆ Use the Transmitter ID DIP switches to select which Transmitter IDs to repeat.
 - ◆ For example, if you have one transmitter, say a Vantage Pro ISS (#6320), transmitting on ID five (5), turn Transmitter ID DIP switch five on and turn all others to off.
 - ◆ For example, if you have two transmitters (and you could have up to eight), say a Vantage Pro ISS (#6320) and a Wireless Temperature Station (#6370), transmitting on IDs four (4) and eight (8), turn Transmitter ID DIP switches four and eight to on and all others to off.

Note: *If you're using only one transmitter, one repeater, and one console, all three devices are set at the factory to broadcast and receive on Davis ID code #1. You won't need to change anything, unless you've got a neighbor broadcasting on the same ID code.*

Choosing a Location

The range of the radio transmission depends on several factors.

Note: *Given the maximum ranges below, the repeater may need to be somewhat closer to the receiver than to the transmitter.*

Typical maximum ranges between the transmitter and the repeater:

- ◆ Line of Sight: 400 feet (120 m)
- ◆ Through Walls and Ceilings: 150 feet (46 m)
- ◆ Through Trees and Foliage: 150 feet (46 m)

Typical maximum ranges between the repeater and the receiver:

- ◆ Line of Sight: 400 feet (120 m)
- ◆ Through Walls and Ceilings: 75 to 150 feet (23 to 46 m)
- ◆ Through Trees and Foliage: 75 to 150 feet (23 to 46 m)

AC-Powered Repeaters

Look for a sheltered location with access to an AC-power outlet. For example, you could mount the repeater in a room or garage.

Solar-Powered Repeaters

Look for a location where you can position the solar panel to receive maximum exposure to the sun's rays as follows:

- ◆ The solar panel works best when the surface of the panel receives full sunlight. Mount the panel away from fences, buildings, trees or other obstructions that may cast shadows over the panel.
- ◆ The solar panel should be mounted facing south in the Northern Hemisphere and north in the Southern Hemisphere for maximum sun exposure.

You can use a compass or a local map to help find north and south.

Testing Proposed Locations

Test your proposed transmitter, repeater and receiver locations to ensure successful data transmission as follows:

1. Make sure your transmitter and receiver are in position and are operating in test mode.

To place the Wireless Repeater in test mode, flip Repeater ID DIP switch #4 to "TEST" and then power the repeater. Refer to the figure on page 3.

Now, verify that the receiver is in test mode. Please refer to your receiver manual to learn how to start the test mode.

In test mode, depending on your model, the transmitter either beeps or flashes when it is transmitting and the receiver beeps or flashes whenever it is receiving data from the transmitter (approximately every 2.5 seconds if the signal is within range).

2. Place the repeater temporarily where you plan to mount it.
Don't complete the installation, because you may need to move the repeater.
3. Apply power to the repeater.

◆ AC-Power Model

Plug the AC-power adapter into the jack marked POWER, and into an AC-power outlet. Watch for the LEDs to light (as described below).

Install three AA-cell batteries for backup power (optional).

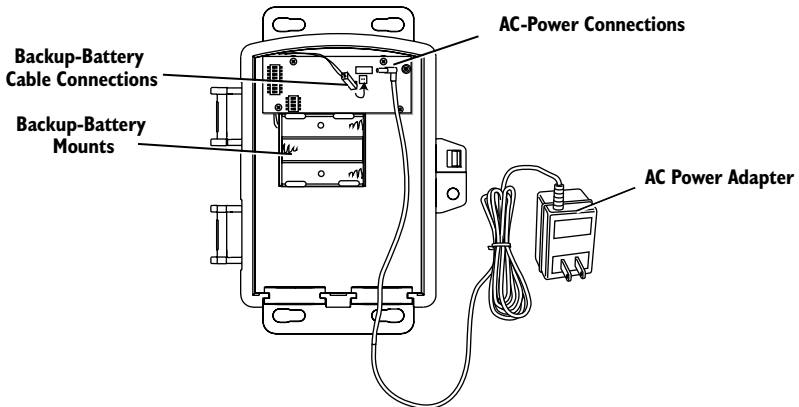

Applying Power to the AC-Powered Repeater

◆ Solar-Power Model

Plug the power cord from the battery to the jack marked POWER as shown below. Watch for the LEDs to light, (as described below).

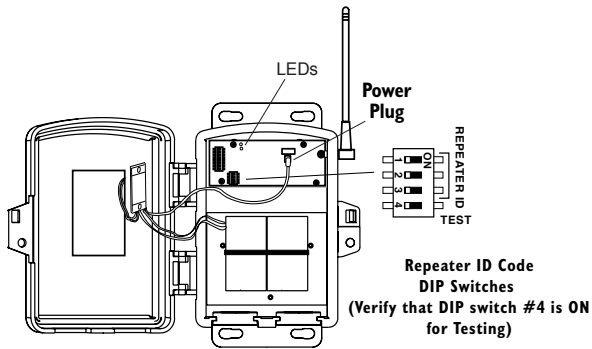

Applying Power to the Solar-Powered Repeater

Both LEDs flash once when you apply power. The repeater performs a self-diagnostic test that lasts about seven seconds. When the test is completed, both LEDs flash again twice. After that second double-flash, the repeater begins listening for a signal. If it finds one, the lower LED flashes as it receives a signal and then the upper LED flashes as the data is transmitted out again.

If the repeater still cannot find a signal one minute after you apply power, it double-flashes three times and then shuts itself down in order to save power. If this happens, check that your transmitter is transmitting and try repositioning your repeater for better reception. Remove and reapply power to the repeater to make it listen for the signal.

Once the repeater receives and re-transmits reliably, check your console/receiver's reception. If you're using a Vantage Pro console/receiver, enter Setup mode. The first screen in Setup mode will show you what transmitters the console is receiving. For other Davis products, the receiver flashes, beeps, or otherwise indicates it received a data packet approximately every 2.5 seconds in test mode. If there is no indication that data has been received, reposition the repeater, transmitter, or receiver for better reception.

Note: *To overcome difficult terrain or excessive obstructions, you can add additional repeaters to boost the signal through—or carry it around—various obstacles.*

-
4. When you find a location that works, switch all three units out of test mode.

If the transmitter is in test mode, restore to normal mode to conserve power. If you're using a Vantage Pro console/receiver, use Setup mode to temporarily deactivate all transmitter IDs. Similarly, to switch the repeater out of test mode, flip the Repeater ID DIP switch #4 from the TEST position to the off position as shown below.

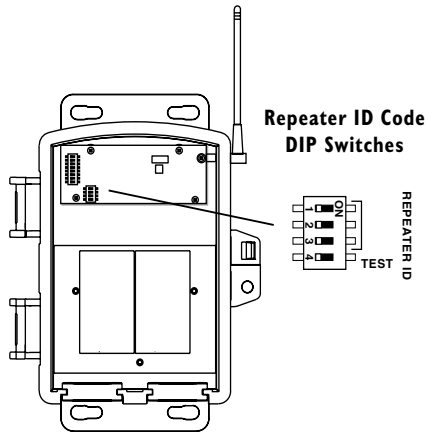

Repeater DIP Switch Set to TEST MODE OFF

Note: Leaving the repeater in test mode will cause the LEDs to flash unnecessarily and thus drain additional power from your power supply. Use the test mode only when necessary.

5. Remove power from the repeater.
For AC models, make sure you unplug both primary and battery power.

Mounting the Repeater

Once you determine that your chosen location transmits and receives the signal, continue with the installation by mounting the repeater. Mounting hardware has been included for the most common installations (see figure on page 9 for instructions).



CAUTION: Any prominent object, including an outside-mounted repeater, can attract a lightning strike. If lightning strikes your unit or strikes somewhere nearby, the unit's internal electronics may suffer. The unit itself has been designed with considerable surge protection, but to safeguard nearby equipment and structures, we recommend following local recommendations on properly *grounding* your installation. For more information, contact your local lightning protection authority and/or refer to the following articles:

- ◆ **MIL-HDBK-419A: *Grounding, Bonding, and Shielding for Electronic Equipments and Facilities*, 29 Dec 1987.**
- ◆ **National Fire Protection Association, 1997: *Standard for Installation of Lightning Protection Systems*, 1997 ANSI/NFPA 780, National Fire Protection Association, Quincy, MA.**
- ◆ **NEC, *National Electrical Code, 1996 Edition*: National Fire Protection Information, Quincy, MA.**

Mounting the Repeater

Mounting the AC-Powered Repeater

1. Choose a location with access to AC power.
2. Mount the shelter against a wall or post, or on a pipe.
See page 9 for figures showing wall or post and pipe mounts.

Mounting the Solar-Powered Repeater

1. Mount the shelter against a wall or post, or on a pipe.

CAUTION: Remember to face the solar panel south in the Northern Hemisphere and north in the Southern Hemisphere for maximum sun exposure.

◆ Wall or Post

Attach the shelter to the mounting surface in the desired location using the lag screws and 1/4" flat washers as shown below.

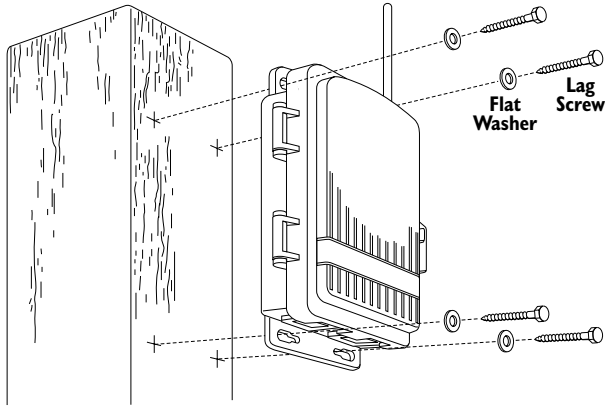

Mounting Repeater on a Wall or Post

◆ Pipe - 3/4" to 1-1/4" (19 cm to 31 cm)

Use the 1-1/2" U-bolts and saddles, and the 1/4" washers and hex nuts as shown below.

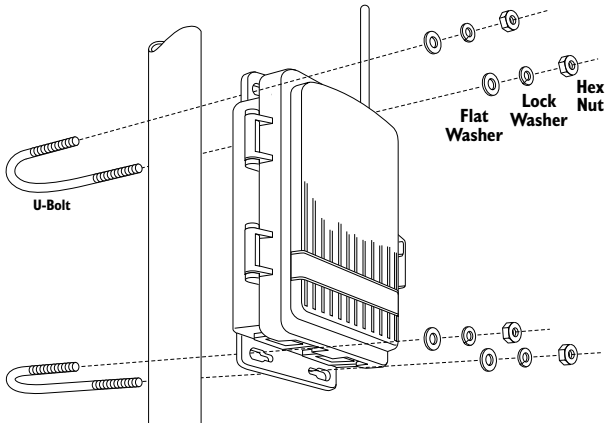

Mounting Repeater on a Small Pipe

2. Apply power (see step 3 on page 5) and close the shelter door.

Advanced Installations

Daisy-Chain Installation (Multiple Repeaters)

To transmit data up to one and a half miles (two and a half kilometers), or to improve reception in hilly, heavily-wooded or urban areas, you can daisy-chain up to eight repeaters together. For instructions on daisy-chaining multiple repeaters, see below; for instructions on adding multiple transmitters to the network as well, see page 12.

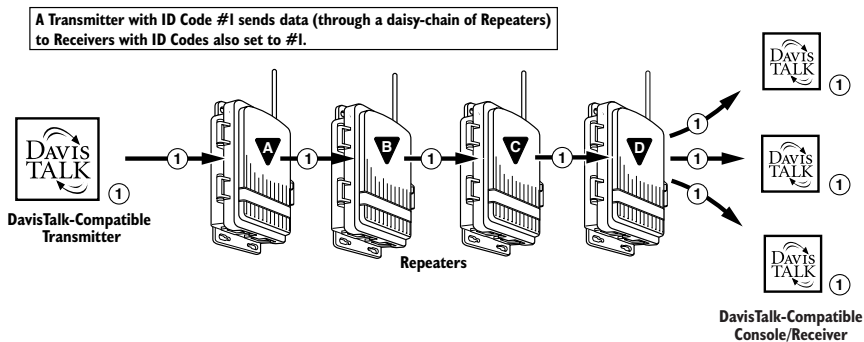

Daisy-Chain Installation - Multiple Repeaters

To install a chain of more than one repeater, follow the instructions for a single repeater installation. Before you apply power to test the system, set Repeater ID codes so that each listens to the repeater before it in succession.

The first repeater (i.e., the repeater closest to the transmitter) needs no adjustment. The second repeater needs to be set to Repeater ID code B; and the third, to C; and so on. In this way, the second repeater (B) only tunes into signals from the first (A), and the third (C) only tunes into signals from the second (B), and so on, thereby improving reception.

Note: *The repeater "closest to the transmitter" means the repeater with the best connection to that transmitter (i.e., whether or not it is the shortest distance away may be less important than a clear line of sight).*

Setting the Repeater ID Codes on the Repeater

To configure each repeater's ID code (except the first), use the table on page 11 to set the Repeater ID DIP switches:

Note: *If you have only one repeater, you do NOT need to set any Repeater ID code DIP switches. If you have more than one repeater, use the chart on page 11.*

<u>REPEAT- ER ID CODE</u>	<u>DIP SWITCH 1</u>	<u>DIP SWITCH 2</u>	<u>DIP SWITCH 3</u>	<u>DIP SWITCH 4</u>
A (default)	off	off	off	The position of this DIP switch is not part of the ID code.
B	off	off	ON	
C	off	ON	off	
D	off	ON	ON	
E	ON	off	off	
F	ON	off	ON	
G	ON	ON	off	
H	ON	ON	ON	

So, for example, the second (B) repeater's DIP switches will be set to OFF, OFF, ON, while the third (C) will be set to OFF, ON, OFF, as shown below.

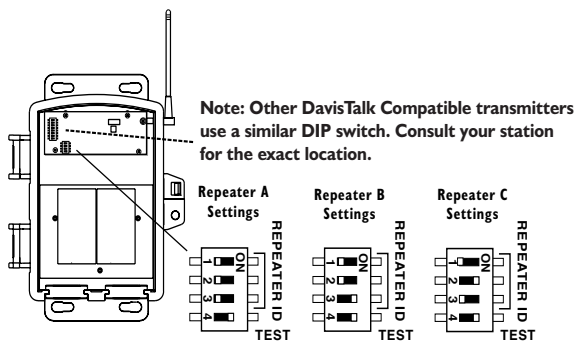

DIP Switches on Repeaters A, B, and C

Setting the Transmitter ID Codes on the Repeater

Once you have set the Repeater ID codes, determine whether you need to set Transmitter ID codes. *If you have only one transmitter and its DIP switches are set to the default ID code (#1), then you do not need to set any transmitter ID codes on the repeater closest to the transmitter. All other repeaters must have all transmitter ID DIP switches turned off.*

If the transmitter's DIP switches are set to some code other than the default (#1), then the *closest* repeater to a transmitter is the only repeater that should have its transmitter DIP switch set to that transmitter's ID code (see "Quick Install Instructions" on page 3 for details). All other repeaters in the chain should have their transmitter DIP switches set to OFF because there is only one transmitter in this chain and its signal is already being picked up.

If you have more than one transmitter, see "Network Installation (Multiple Transmitters)" on page 12. Otherwise, simply continue with the installation where you left off (see "Choosing a Location" on page 4).

Network Installation (Multiple Transmitters)

If you have two or more transmitters in your network, follow the instructions as if for a multiple repeater installation. Before you apply power to test your chosen locations, set unique ID codes for each transmitter and then set the closest repeater to each transmitter to listen to that transmitter.

Note: Each transmitter in your network must have a different ID code so that its signal remains distinct and identifiable throughout the network. See your *Wireless Weather Station* or the appropriate *DavisTalk™ compatible product manual* for instructions on how to set the *Transmitter and Receiver ID codes*.

There are a number of ways you can configure your network. The only rule is that each transmitter's data should only enter the network at one point, through one repeater. No two repeaters should be set to listen to the same transmitter directly.

◆ Multiple Transmitter Network

You can set one repeater to listen to up to eight transmitters directly, and then re-transmit those signals to your consoles. To set the repeater to listen to each transmitter, flip the appropriate DIP switches on the repeater.

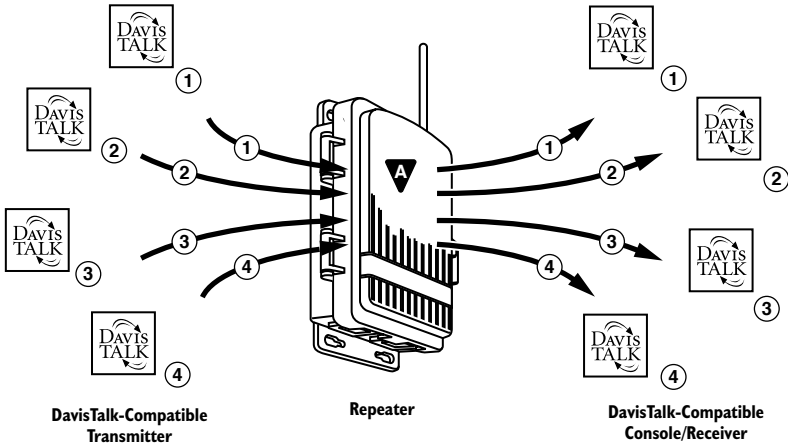

Multiple Transmitter Network

In the diagram above, the Repeater/Transmitter ID DIP switches (eight switches on DIP switch) would have #1, #2, #3, and #4 set to ON, and the rest set to OFF.

The Repeater's ID code DIP switches (four switches on DIP switch), on the other hand, would simply be set to default ID code A (OFF, OFF, OFF) because the repeater in the above diagram does not need to listen to any other repeaters.

◆ Combo Network — Multiple Transmitters AND Multiple Repeaters

A combo network can have any combinations of the multiple transmitter network on page 12 and the daisy-chain network on page 10. In the example below, the data all flows in one direction; it enters the network at a point somewhere upstream and exits the network somewhere downstream.

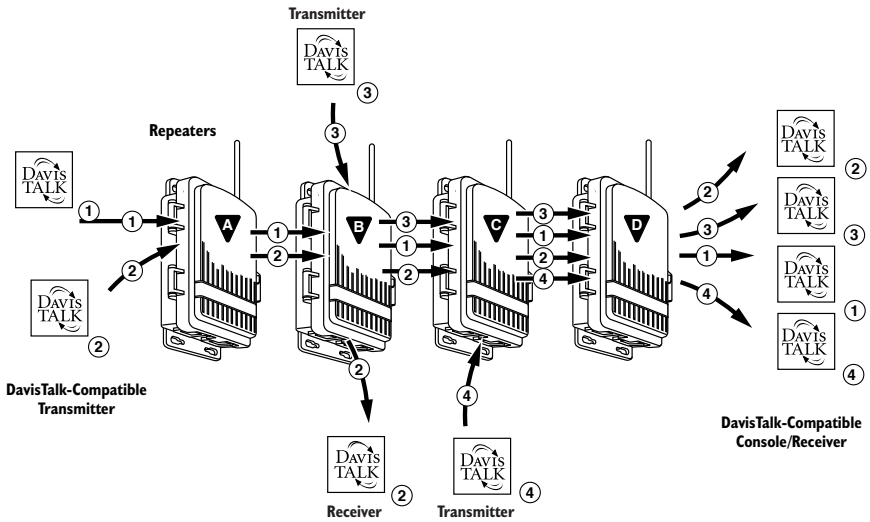

Combo Network- Multiple Transmitters and Multiple Repeaters

Note: No matter how closely they are spaced, no two repeaters should be set up to listen to the same transmitter directly—this only generates interference and can cause the network to fail.

To set up a network:

1. Set ID codes for each transmitter and receiver.
See your DavisTalk-compatible transmitter and receiver installation manual for instructions on how to set transmitter and receiver ID Codes.
2. Choose locations for the farthest transmitter, its repeater and its receiver.
Set the repeater to listen for that transmitter’s signal (see “Quick Install Instructions” on page 3 for details). Make sure the repeater is receiving and then re-transmitting the signal properly.
3. Add any additional repeaters as necessary, one at a time.
Make sure you set each one’s Repeater ID code (see “Setting the Repeater ID Codes on the Repeater” on page 10 for details).
4. Put all the units in test mode to test the transmission of the data from the transmitter, through each repeater, to the receiver.

-
5. Turn off the “farthest” transmitter and then add the second farthest transmitter (and its receiver) to your network. Check the reception of that second signal at each point.
Ensure that your network is functioning properly at every stage so that if, at some point, you add a transmitter, repeater, or receiver that is malfunctioning or is poorly positioned, you will know immediately.
 6. Add additional transmitter/receiver pairs one at a time, making sure to test only one signal (i.e., one pair) at a time.
 7. Once each transmitter/receiver pair has been tested by itself, add signals (i.e., the transmitters you tested above) slowly to the network as follows:
 - A. Turn all the repeaters off. Turn off all transmitter ID DIP switches except Transmitter 1 DIP switch.
 - B. Turn on Transmitter 1 and Repeater A only. Verify that Repeater A is retransmitting Transmitter 1 by observing the LED (as illustrated on page 6.)
 - C. Apply power to repeaters B, C, and D. Data is transmitted and repeated to the consoles/receivers through repeaters B, C, and D.
 - D. Turn on Transmitter 2 and flip DIP switch #2 on Repeater A to ON. Data is transmitted and repeated to the consoles/receivers through repeaters B, C, and D.
 - E. Turn on Transmitter 3 and flip DIP switch #3 on Repeater B to ON. Data is transmitted and repeated to the consoles/receivers through repeaters B, C, and D.
 - F. Turn on Transmitter 4 and flip DIP switch #4 on Repeater C to ON. Data is transmitted and repeated to the consoles/receivers through repeaters C, and D.

Note: *The steps above tell how to set up and test a network like the network illustrated on page 13. The exact steps vary according to your particular repeater, transmitter and receiver combination.*

If a repeater is set to listen for more than one signal, the repeater waits until it has acquired all the signals you have told it to listen to before it begins repeating. If it fails to acquire one or more of the signals after one minute, the repeater will begin repeating the signals it has found and will check again for the missing signals once every hour.

Note: *If the repeater fails to acquire any signals at all, it will time out after one minute. Reposition the repeater, check that its DIP switches are set correctly and that the transmitter/repeater it is listening for is functioning properly, and then power the repeater up again.*

Whether the repeater acquires all the signals or not, the LEDs flash three times. For each successful transmission of a signal, the lower LED flashes, followed by the upper LED. Count the number of distinct pairs of flashes to determine if any signals are missing.

-
8. Take all transmitters, repeaters, and receivers out of test mode. Consult your installation manuals to find out how to take the units out of test mode. Leaving any of the units in test mode drains power.

Troubleshooting

Please check the troubleshooting list below if you experience a problem with your unit. If you still are unable to solve the problem, we encourage you to call Technical Support at (510) 732-7814 for assistance (Mon-Fri, 7:00am – 5:30pm Pacific Time).

Note: Please do not return your unit for repair without prior authorization.

Note: Repeater ID DIP switch 4 must be set to ON to for the LEDs to light.

◆ **The LEDs do not flash on power-up.**

Make sure that your power cord connections are secure. If your unit is AC-powered, try plugging the repeater into another outlet and some other (functioning) device into the outlet you are using.

If your unit is solar-powered and the rechargeable battery is over five years old, try replacing the battery. (Do not incinerate the used battery, it may burst. Arrange for proper recycling in your locality.)

If your unit is solar-powered and the battery is less than five years old, make sure the panel is not being shaded by the sun. Open the shelter and check that the wire connections are secure and that the battery is free from corrosion and excessive deposits on the terminals. Clean the solar panel using a water spray, or a soft cloth and soapy water followed by a clean water rinse. Check the battery's voltage with a voltmeter; the battery must have at least 3.8 V to power the station. (More than 4 V indicates an adequately charged battery.) Try exposing the panel to ample sunlight for a week, or use a charger designed to recharge a 4 V gel cell battery.

◆ **The LEDs do not flash twice after the self-diagnostic.**

Upon power-up, if you consistently get a first flash but no double-flash seven seconds later, something is wrong with the unit's circuitry. Please contact Technical Support for assistance (see above).

◆ **The lower LED is not lighting up, but the upper one is.**

When the repeater fails to receive a valid data packet, it still sends out a "no data" packet to keep downstream repeaters in sync. Even if no data packet is received, the lower *receive LED* will not light but the upper *transmit LED* will. This is useful in a network situation because it can show where the last good packet was received in a chain of repeaters.

If the lower LED consistently fails to light up, make sure the transmitter (or repeater) that it is listening to is powered up and functioning correctly. You can also try moving the repeater closer to the transmitter (or prior repeater) for better reception.

Specifications

Operating Temperature	-40° to +150°F (-40° to +65°C)
Non-operating Temperature	-50° to +158°F (-45° to +70°C)
Current Draw	1.5 mA at 4-6 VDC
Dimensions6.25" x 2.25" x 7.875" (158.75 mm x 57.15 mm x 200 mm)

Wireless Communications

Transmit/Receive Frequency	US Models: 916.5 MHz, Overseas Models: 868.35 MHz
ID Codes Available8
Output Power916.5 MHz: FCC-certified low power, less than 1 mW, no license required 868.35 MHz: CE-certified, less than 10 mW, no license required
RangeLine of Sight - up to 400' (122 m) Through Walls - 75 to 150' (23 to 46 m)

FCC Part 15 Class B Registration Warning

This equipment has been tested and found to comply with the limits for a class B digital device, pursuant to Part 15 of the FCC Rules. These limits are designed to provide reasonable protection against harmful interference in a residential installation. This equipment generates, uses and can radiate radio frequency energy and, if not installed and used in accordance with the instructions, may cause harmful interference to radio communications. However, there is no guarantee that interference will not occur in a particular installation.

If this equipment does cause harmful interference to radio or television reception, which can be determined by turning the equipment off and on, the user is encouraged to try to correct the interference by one or more of the following measures:

- ◆ **Reorient or relocate the receiving antenna.**
- ◆ **Increase the separation between the equipment and receiver.**
- ◆ **Connect the equipment into an outlet on a circuit different from that to which the receiver is connected.**
- ◆ **Consult the dealer or an experienced radio/TV technician for help.**

Shielded cables and I/O cords must be used for this equipment to comply with the relevant FCC regulations. Changes or modifications not expressly approved in writing by Davis Instruments may void the user's authority to operate this equipment.

Product Numbers: 7624 & 7625
Davis Instruments Part Number: 7395.105
Wireless Repeater with Solar or AC-Power
Rev. E (September 9, 2003)

This product complies with the essential protection requirements of the EC EMC Directive 89/336/EC.
Copyright © 1999-2003 Davis Instruments Corp. All rights reserved.



3455 Diablo Avenue, Hayward, CA 94545-2778
510-732-9229 • Fax: 510-732-9188
E-mail: info@davisnet.com • www.davisnet.com