

SIROCCO INSTALLATION

PROPER INSTALLATION IS IMPORTANT. IF YOU NEED ASSISTANCE, CONSULT A CONTRACTOR, ELECTRICIAN OR TELEVISION ANTENNA INSTALLER (CHECK WITH YOUR LOCAL BUILDING SUPPLY, OR HARDWARE STORE FOR REFERRALS). TO PROMOTE CONFIDENCE, PERFORM A TRIAL WIRING BEFORE INSTALLATION.

- 1 Determine where you are going to locate both the rooftop sensor and the read-out.

Feed the terminal lug end of the 2-conductor cable through the rubber boot and connect the lugs to the terminals on the bottom of the wind speed sensor. (Do NOT adjust the nuts that are already on the sensor). The polarity does not matter.

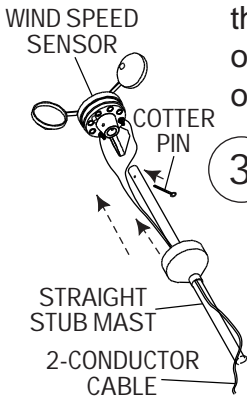
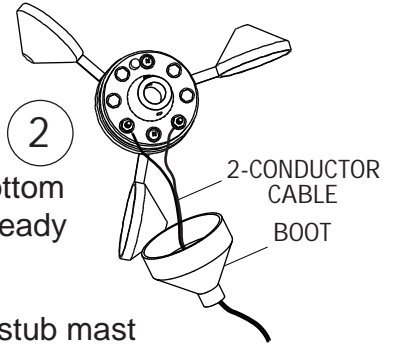

- 3 Slide the stub mast through the rubber boot and insert the stub mast into the bottom of the wind speed sensor. Secure with the cotter pin. Coat all connections with silicone sealant and slip the boot over the sensor.

Secure the sensor and the stub mast to your antenna mast (not supplied) with the two hose clamps. Radio Shack and similar stores have a selection of antenna masts and roof mounting brackets. Choose a mount that best suits your location and provides at least eight feet of vertical clearance above objects on the roof.

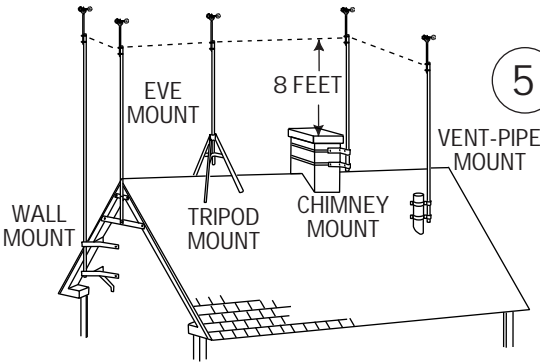
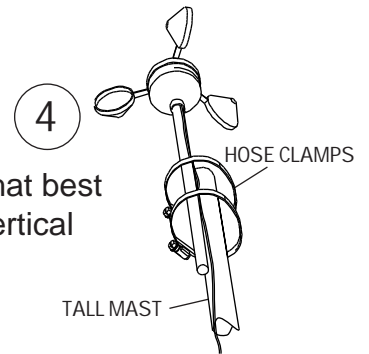

- 5 Follow the instructions supplied with the antenna mount and secure the mast to the mount.

Secure the wire to the building using cable clips (do not use regular staples). Form a drip loop where wire enters hole drilled through the exterior wall. Caulk the hole when done.

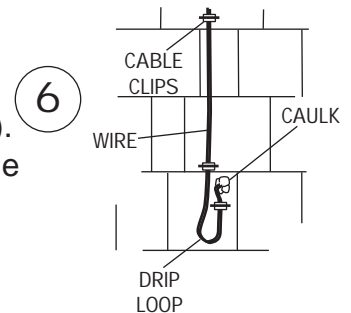

- 7 Feed the cable through the wall to where the read-out is going to be located. Attach the wires to the rear of the read-out as shown. (Do NOT adjust the nuts that are already on the meter). The polarity does not matter.

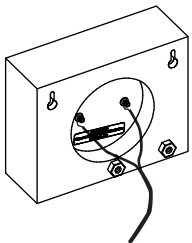

The Sirocco read-out is free standing. It can also be mounted on a wall using the key hole cut outs in the back of the instrument's wood block.

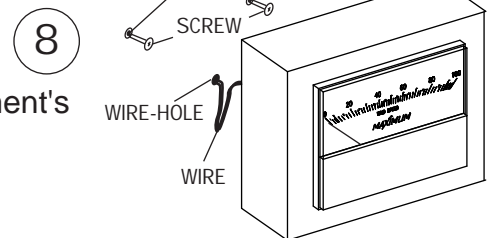

MAXIMUM INC.

Samuel Barnett Boulevard
New Bedford, MA 02745
(508) 995-2200

SIROCCO

OPERATION

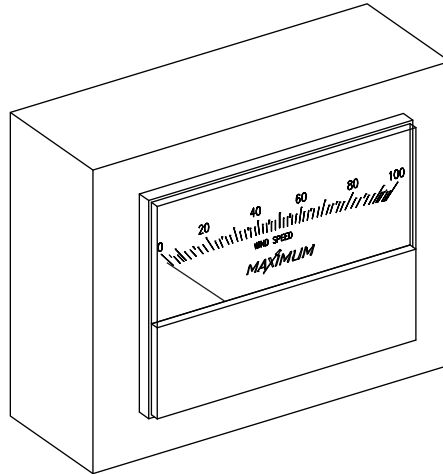

The Sirocco is a self-powered wind speed measuring instrument. It does not need batteries or an external power supply. In normal operation it requires no maintenance.

ADDITIONAL INFORMATION

Cables can be shortened or lengthened without affecting accuracy

WIRE GAUGE	MAXIMUM FEET WITHOUT RECALIBRATION	WIRE GAUGE	MAXIMUM FEET WITHOUT RECALIBRATION
24	300'	16	2000'
22 (supplied with instrument)	500'	14	3200'
20	750'	12	5000'
19	1000'	10	8000'
18	1250'		

TROUBLE SHOOTING

Maximum Instruments are accurate and reliable. Most problems that occur are due to loose or corroded connections. If, after checking the connections, there is still a problem, determine if the problem is with the sensor or the brass read-out.

- If there is wind
- ① Disconnect the wires from the back of the read-out.
 - ② Attach a low range *AC Analog Voltmeter* to the wires. If the sensor is operating properly, you will achieve these approximate readings: 8-9 MPH = 0.15 VAC rms, 17 MPH = 0.31 VAC rms, 51 MPH = .97 VAC rms, 102 MPH 2.0 VAC rms
 - ③ If the sensor delivers these approximate readings, then the read-out is faulty. If the sensor does not produce these readings, then either the sensor or the wire is faulty.

- If there is no wind
- ① Disconnect the wires from the back of the read-out.
 - ② Connect an *ohm meter* to the wires.
 - ③ The *ohm meter* should indicate between 500 and 1,000 ohms.
 - ④ If there is a good reading on the *ohm meter*, then the read-out is faulty. If the reading is bad, then the sensor or wire is faulty.

MAXIMUM INC.
 Samuel Barnett Boulevard
 New Bedford, MA 02745
 (508) 995-2200

IMPORTANT ADDITIONAL INFORMATION

Components: Along with the indicator, the following components are included with this instrument:

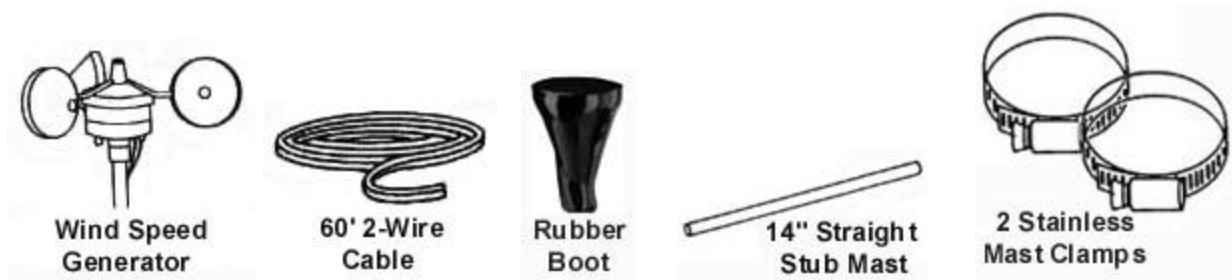

Rooftop sensor: To insure a clear unobstructed path for the wind to the sensor, it should be mounted on some type of antenna mast at least 8-10' above the highest object on your roof. Remember, your roof is also an obstruction and it usually requires at least 8' of height to avoid the turbulence it creates.

Sensor: Properly installed, your sensor will require virtually no maintenance at all. Our sensors do not utilize brushes or wiping contacts. All bearings are Rulon-J self lubricating type and will perform for many years in the harshest environments.

Specifications: All instrumentation or measuring devices have accuracy tolerances and specifications. Making comparisons between different pieces of equipment is appropriate provided the specified accuracies of both are known.

	Measurement Range	Guaranteed Accuracy
Wind Speed	0-100 MPH	±3% Full Scale & Mid Scale